

# MP4824-xx Series

## Low Voltage DC-DC Converters

Prodrive Technologies' DC-DC Converters are part of our larger eMobility and Power Conversion Portfolio. These fully bidirectional DC-DC converters are scalable and very efficient solution for demanding industrial and off-road applications and mild hybrid automotive systems/vehicles. They can be used to supply all power-intensive auxiliary applications and recuperate braking energy. Due to its very slim and highly energy efficient design it is ideally suited to be integrated into the battery itself. The wide DC voltage range supports multiple battery voltages.

### Features

- Fully Bi-Directional
- Multiphase scalability
- EMC filters included
- Overvoltage, Overcurrent, Overtemperature Protected
- Short-circuit and Under voltage protected
- Reverse Polarity Protected
- 227mm x 233mm x 62mm
- IP69K Rated
- CAN Interface / J1939
- 95% Efficiency
- RoHS Compliant

## Model Selection

Model	Amps (A)	Watts (W)	High Side Voltage (V)	Low Side Voltage (V)	Efficiency (%)	Operating Temperature	Cooling Method
MP4824-150	150	3600	36 – 54	18 – 32	95	-40°C to 75°C	Forced Air

## Functional Description

### Top level block diagram

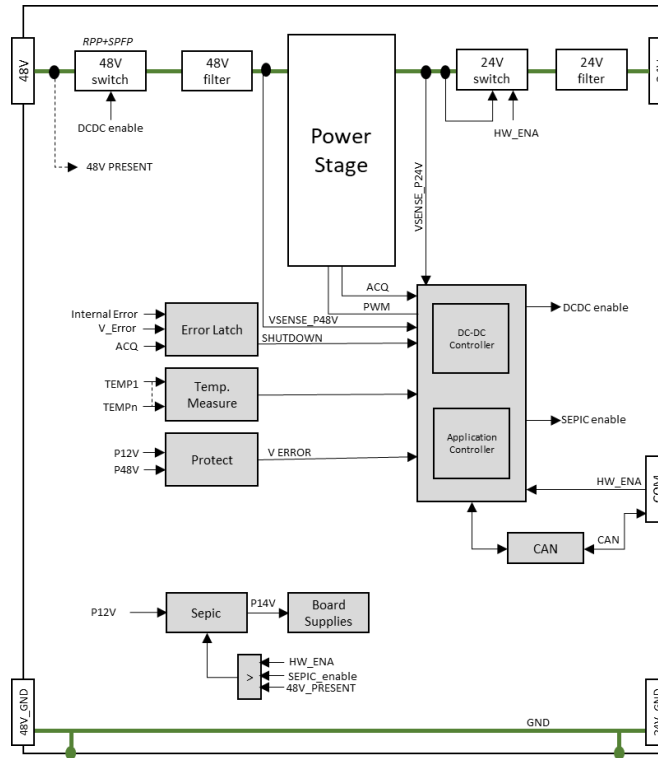

## 48V: High Side

Mnemonic	Description/Conditions	Min	Nom	Max	Unit
V <sub>48n</sub>	Nominal terminal voltage range	48	50.5	53	V <sub>DC</sub>
V <sub>48min,limited</sub>	Limited terminal voltage range. For limited operation specification	24		48	V <sub>DC</sub>
V <sub>48max,limited</sub>		53		54	V <sub>DC</sub>
V <sub>48ovp</sub>	Over voltage protection	54	57	60	V <sub>DC</sub>
V <sub>48uvp</sub>	Under voltage protection	20		24	V <sub>DC</sub>
V <sub>48sleep-mode</sub>	Absolute terminal voltage in sleep mode			1	V <sub>DC</sub>
V <sub>48ripple</sub>	Generated voltage ripple for V <sub>56n(Nom)</sub> , I <sub>12n(Min)</sub> (V48Control -mode)			4.8	V <sub>RMS</sub>
η <sub>12</sub>	Electrical efficiency at I <sub>24n(Min)</sub> , V <sub>24n(Min)</sub> , V <sub>48n(Nom)</sub> and T <sub>AMB</sub> =25°C during V48Control-mode	94	95		%

- Disable 48V before connection or disconnection of terminals.
- The 48V input is protected against reversed polarity connection.
- The 48V connection is protected to input over currents by external fuses.
- The 48V output is protected against over current and short-circuit.

## 24V: Low Side

Mnemonic	Description/Conditions	Min	Nom	Max	Unit
$V_{24n}$	Nominal terminal voltage range	20	24	30	$V_{DC}$
$V_{24min,limited}$	Limited terminal voltage range. For limited operation	16		20	$V_{DC}$
$V_{24max,limited}$	specification, see	30		32	$V_{DC}$
$V_{24ripple}$	Generated voltage ripple, for $V_{24n(Nom)}$ , $I_{24n(Max)}$ (V24Control-mode),			0.7	$V_{PP}$
$I_{24ocp,3.6kW}$	Over Current Protection		$\pm 165$		A
$\eta_{56}$	Electrical efficiency at $I_{24n(Max)}$ , $V_{24n(Nom)}$ , $V_{56n(nom)}$ and $T_{AMB}=25^{\circ}C$ during V24Control-mode	94	95		%
$I_{12leak}$	Leakage current into $V_{24}$ when drive switched-off for $T_{AMB}\leq 40^{\circ}C$			500	$\mu A$

-The 24V connector is voltage hot pluggable for voltage, but not for current. First disable MP5624-50 before disconnection of terminals.

-The 24V input is protected against reversed polarity connection.

-The 24V connection is protected to input over currents by external fuses.

-The 24V output is protected against output over current and short-circuit.

-The 24V input/output is not protected against short circuit to the 56V terminal.

(Short circuit from CN\_56V to CN\_24V potentially leads to an internal short circuit between the two contacts)

## Digital Inputs

Active high signal from the external controller which will enable the MP5624-xx hardware.

Hardware enable inputs:

Mnemonic	Description/Conditions	Min	Nom	Max	Unit	Remark
$V_{HW\_ENA}$	Input voltage	-32	24	32	[V]	
$V_{HW\_ENA,HI}$	Input logic high level voltage (relative to GND)	6			[V]	Active high
$V_{HW\_ENA,LO}$	Input logic low level voltage (relative to GND)			1	[V]	
$V_{HW\_ENA,CM}$	Input voltage range common mode (relative to housing)	-0.5		0.5	[V]	
$V_{HW\_ENA,HYST}$	Input logic level hysteresis	100			[mV]	
$I_{IN}$	Input current, nominal operating conditions			2	[mA]	
$I_{HW\_ENA,GND}$	Maximum GND current			1	[A]	
$T_{HIGH}$	Minimum uninterrupted high time, $V_{IN}>V_{IN,HI}$	0.1			[s]	
$f_{C,IN}$	Cut-off frequency input filter		1		[kHz]	3dB roll-off

Principle circuit diagram of HW enable input:

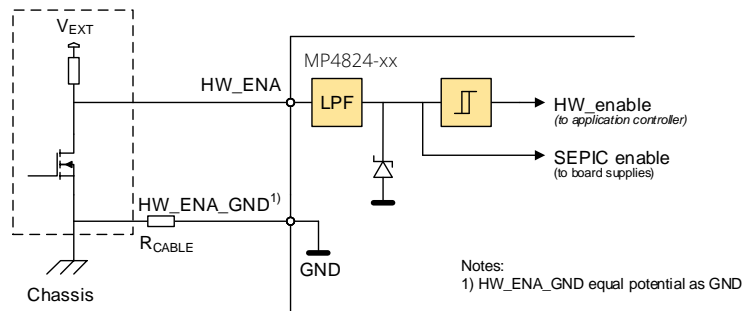

## Software

### CAN J1939

J1939 is used on CAN for communicating with the application controller.

Mnemonic	Description/Conditions	Min	Nom	Max	Unit	Remarks
Bitrate	Bitrate		250	1000	[kbps]	
t <sub>SAMPLE</sub>	Sample point		87.5		[%]	
l <sub>INT</sub>	Internal stub length			0.3	[m]	
R <sub>term</sub>	Termination resistors		none		[-]	Termination shall be applied externally
Interface	Physical interface		ISO-11898-2:2003		[-]	Short-circuit proof in 24V systems (Not short-circuit proof to 48V terminal)

## Control Behavior

In V24Control-mode the controller operates in voltage control mode and current control mode simultaneously.

Converter performance specifications in V24Control-mode<sup>1)</sup>

Mnemonic	Description/Conditions	Min	Nom	Max	Unit
V <sub>24,OS</sub>	24V terminal voltage overshoot as a result of load decrease			1.5	V
V <sub>24,US</sub>	24V terminal voltage undershoot as a result of load increase			1.5	V
dl <sub>24</sub> /dt	Maximum 24V load current change; no battery connected			10	kA/s
	Maximum 24V load current change; battery connected			inf	kA/s
l <sub>24,OFFSET</sub>	Steady state offset error of the 24V output current	-3	0	3	A
l <sub>24,GAIN</sub>	Steady state gain error of the 24V output current	-5	0	5	%

In V48Control -mode the controller operates in voltage control mode and current control mode simultaneously. The 48V current is not measured, the current regulation is based on the calculated current. The 48V current is calculated using V<sub>48</sub>, I<sub>24</sub>, V<sub>24</sub> and an efficiency of 95%.

Converter performance specifications in V48Control -mode<sup>1)</sup>

Mnemonic	Description/Conditions	Min	Nom	Max	Unit
V <sub>48,OS</sub>	48V terminal voltage overshoot as a result of load decrease			3	V
V <sub>48,US</sub>	48V terminal voltage undershoot as a result of load increase			3	V
dl <sub>48</sub> /dt	Maximum 48V load current change; no battery connected			10	kA/s
	Maximum 48V load current change; battery connected			inf	kA/s

## Environmental Conditions

Operating and storage climatic conditions<sup>1)</sup>

Parameter	Description	Min	Typ	Max	Unit	Remarks
T <sub>AMB</sub>	Operating ambient temperature	-40		75	[°C]	Ambient temperature directly outside the MP4824-X enclosure @ sea level.
RH <sub>AMB</sub>	Operating humidity	0		100	[%]	Outside relative humidity (condensation possible)
T <sub>AMB,STORE,LT</sub>	Long term storage ambient temperature	-40		85	[°C]	
RH <sub>AMB,STORE</sub>	Storage humidity	0		95	[%]	Outside relative humidity (condensation possible)

1) Long-term high-temperature storage or extended use at maximum temperature conditions may result in a reduction of overall lifetime

## Mechanical

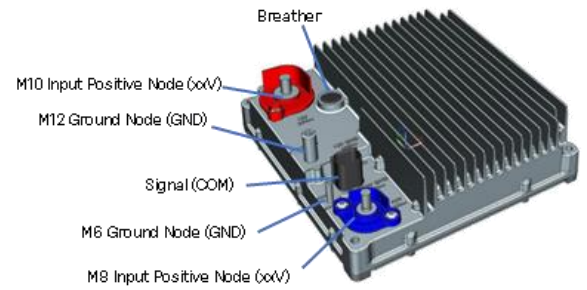
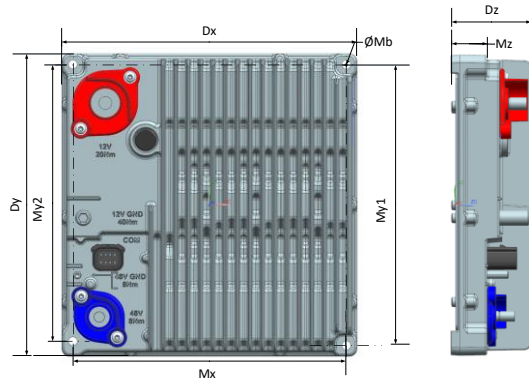

Parameter	Description	Min	Typ	Max	Unit
DX	MP4824-X length x		226.8		[mm]
DY	MP4824-X length y		233		[mm]
DZ	MP4824-X length z	61.2	61.6	62.0	[mm]
My1	MP4824-X mounting position y1		216.3		[mm]
My2	MP4824-X mounting position y2		213		[mm]
Mx	MP4824-X mounting position x		210		[mm]
Mz	MP4824-X mounting position z	27.2	27.7	28.2	[mm]
Mb	MP4824-X mounting diameter		6.8		[mm]

## Weight

Parameter	Unit (kg)
M <sub>MP4824-150</sub>	3.2

## Installation & Mounting Orientation

The mounting orientation and the airflow direction should be according to mounting orientation as shown below.

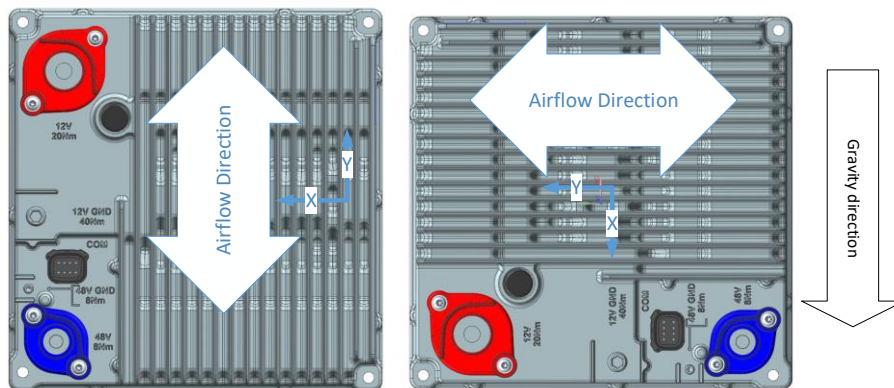

## Airflow Requirements

Description	Min	Typ	Max	Unit
Air speed at surface of the heat sink for MP4824-150	3.0			[m/s]

## Lifetime & Reliability

Parameter	Description	Min	Unit
$t_{LIFE}$	Expected lifetime with mission profile as define in chart below	10	[years]
$t_{LIFE\_flash}$	Flash endurance (program/erase cycles)	100	[kCycles]

MP4824-150 output load profile representing the normal lifetime behaviour

Item	Description	Value	Unit	Remarks
$T_{AMB}$	Ambient temperature	32	[°C]	
$V_{48n}$	Input terminal voltage	48	[V <sub>DC</sub> ]	
$V_{24n}$	Input terminal voltage	24	[V <sub>DC</sub> ]	
$I_{24n}$	Output current	50	[A <sub>DC</sub> ]	V24Control-mode
$v$	Air speed at surface of the heat sink (v)	1.0	[m/s]	
	DCDC restarts per day (I <sub>12n</sub> temporary to 0A)	15	[cycles/day]	
$T_{ON}$	Operational time (I=I <sub>12n</sub> )	19	[min per cycle]	57min total per hour
$T_{OFF}$	Non-operational time (I=0)	1	[min per cycle]	3min total per hour
	Average operational hours per day	6.8	[h]	
	Average operational hours per year	2400	[h/year]	

## Safety & Regulatory Compliances

Reference	Standard	Classification/Conditions
Operational Climate Tests	NEN-EN-IEC60068-2-1:2007 (Ad) (Cold temperature)	FSC A
	NEN-EN-IEC60068-2-2:2007(Be) (Dry heat)	FSC A
	NEN-EN-IEC60068-2-14 (Nb) (Thermal Cycling)	FSC A
	NEN-EN-IEC 60068-2-30 (Db) (Dewing test)	FSC A
	NEN-EN-IEC 60068-2-78 (Cab) (Damp heat steady state)	FSC A
Non-operational Climate Tests	NEN-EN-IEC60068-2-52 (Kb) (Salt Spray)	FSC A (after test)
	NEN-EN-IEC60068-2-1:2007 (Ab) (Cold test)	FSC A (after test)
	NEN-EN-IEC60068-2-2:2007(Bb) (Dry heat)	FSC A (after test)
	NEN-EN-IEC60068-2-14 (Na) (Temperature Shock)	FSC A (after test)
Operational Shock & Vibration Tests	ISO 16750-3:2012(E), Section 4.2.2	FSC A
	ISO 16750-3:2012(E), Section 4.1.2.7	FSC A
Ingress Protection	ISO 20653:2006	FSC A
	ISO20653	FSC A
Chemical Loads	ISO 16750-5:2010(E)	Road vehicles — Environmental conditions and testing Code B (Engine compartment)
	ISO16750-5	
12V Immunity	ISO 16750-2 / Test A (Unclamped load dump)	FSC B
	ISO 16750-2 (Jump Start)	FSC C
	ISO 16750-2 (Reverse polarity)	FSC C
	ISO 16750-2 (Starting profile / cold crank)	FSC B
EMC Standards	IEC 61000-4-4:2004	CE compliancy, §6.6.2.2
	IEC 610004-2:2008	CE compliancy, §6.6.2.2
	E/EC/E/324/Add.9/Rev.5 (UN ECE R10 Rev.5)	UN ECE compliancy, §6.6.2.1
	IEC 61000-4-8:2009	EMC Test & Measurement, Field Immunity Test (CE)
	CISPR 25:2008 (NEN-EN55025)	UN ECE R10 compliancy
	ISO 11452-2:2004	UN ECE R10 compliancy
Immunity: Enclosure	ISO 11452-8:2007,IDT	UN ECE R10 compliancy
	ISO 11452-2 ALSE	FSC B
	IEC 61000-4-3	FSC A
	ISO 11452-8	FSC A
	IEC 61000-4-8	FSC A
Immunity: LV / HV Supply	IEC 61000-4-2, ESD	FSC A (unpowered) / FSC B (powered)
	ISO 7637-2, pulse 1 (inductive switching)	FSC C
	ISO 7637-2, pulse 2a (inductive switching)	FSC B
	ISO 7637-2, pulse 2b (inductive switching)	FSC C
	ISO 7637-2, pulse 3a (switching spikes)	FSC A
	ISO 7637-2, pulse 3b (switching spikes)	FSC A
	ISO 11452-4 BCI	FSC B
Immunity: Signal Line	ISO 7637-3, fast pulses a and b	FSC C
	ISO 7637-3, slow pulses	FSC C
	IEC 61000-4-4	FSC A
Safety Standard: CE	NEN-EN-IEC 62477-1:2012	CE

#### Copyright License

This chapter contains the software license information of the license of the software written by Prodrive and of any third party software used.

##### B.1. License information

Prodrive ensures the delivered "application" of the whole source code is not required to be released to the end-customer by the license requirements of any used 3rd party software. Exception is the 3rd party "open source" code where sections of the code need to be made available for the end-customer. See section B.2 for more information for the used 3rd party software.

The software written by Prodrive is considered proprietary and thus has no requirements to be made available for the end-customer. The following license information will be included in the source code:

```
/* Copyright (C) Prodrive Technologies B.V. - All Rights Reserved
 * Unauthorized copying of this file, via any medium is strictly prohibited
 * Proprietary and confidential
 * Written by Author <Author@Prodrive-technologies.com>, <Date>
 */
```

##### B.2. Open Source License Information

The following clause is required in the user manual of the product.

Prodrive Technologies B.V. (Prodrive) uses open source software in selected products. Where Prodrive has modified open source packages licensed under the GNU Public License (GPL), Prodrive is required to make this code available to customers under the terms of the license. The purpose of this document is to provide a list of open source packages currently utilized and/or modified by Prodrive, as well as provide information for how Prodrive customers may request a copy of the GPL source code present in the product(s) they own.